

RETROFIT OF A METROPOLITAN MIDRISE TO IMPROVE TORSIONAL RESPONSE USING NONLINEAR FLUID VISCOUS DAMPERS

Michael Gemmill¹, Kurt Lindorfer¹, H. Kit Miyamoto²

ABSTRACT

In many metropolitan areas, midrise buildings are constructed adjacent to existing buildings, and incorporate concrete shear walls to act as a barrier between the two buildings. The orientation of these shear walls often causes severe torsional response within the building. The addition of a few well-placed nonlinear Fluid Viscous Dampers (FVD's) can significantly decrease the torsional excitation, thereby increasing building performance.

The project involves the retrofit of an 18-story steel frame building that exhibits severe torsional response from the "property line" condition at the lower two stories. The FVD's significantly reduce the displacement and acceleration of the second and third floors of the building, where sensitive telecommunications equipment is being housed. They reduce the demand and drift on the stories above with no additional construction required on these floors.

FVD's offer a very economical and effective means of mitigating undesirable building response due to torsional irregularities. Their use would be effective in the retrofit of many existing buildings with similar "property line" conditions.

Introduction

In an urban environment, where land costs can be at a premium, new buildings are often constructed directly adjacent to one or more buildings. Many of these buildings are constructed with continuous concrete shear walls along the property lines that are adjacent to the existing building(s), while utilizing steel or concrete moment frames throughout the remainder of the building footprint. This is especially prevalent where the site is located on a corner parcel where street frontage is desired. This design philosophy, which can be witnessed time and time again throughout many metropolitan areas, can often produce an undesirable torsional response within the building. This torsional irregularity can cause severe interstory drifts, leading to poor performance in a seismic event.

Prior to the 1976 Uniform Building Code, no specific drift criterion was required for the design of structures. With no drift requirement in place, the differential stiffness, although possibly acknowledged by the designer, was allowed by the building code. Current procedures, however, recognize that displacement evaluation is a crucial ingredient in the design and analyses of buildings. This displacement-based philosophy can be especially useful when evaluating and retrofitting existing buildings.

¹PARADIGM Structural Engineers, Inc., 251 Kearny Street, 7th Floor, San Francisco, CA 94108,

² Marr Shaffer & Miyamoto Structural Engineers, Inc., 1450 Haylard Dr., Suite One, West Sacramento, CA 95691

Building Description

The project consists of an 18-story office building (see Figure 1) in downtown Oakland, California, built in the mid-1950s. The building footprint is approximately 100 ft. by 225 ft. The lowest two stories exhibit the property line condition described previously. Two-story continuous 12" thick concrete shear walls are located on south and east sides of the building, as shown in Figure 1. The balance of the bays at the lower two stories consists of ordinary steel moment frames. Stories three through eighteen consist solely of ordinary steel moment frames. The building plan steps back 30' above the third floor on the south side, making the floor plan 70 ft. by 225 ft. for stories four through eighteen. The moment frames utilize a variety of welded and bolted moment connections.

The tenant, our client, was interested in occupying the 2nd and 3rd floors to house sensitive communication equipment. To provide backup power to this equipment, the client desired to add a large quantity of UPS batteries, weighing in excess of 450 psf. to a portion of the 2nd floor. Additionally, a large amount of conduit and ductwork was to be suspended from the underside of the 3rd floor, essentially doubling the design loads at the 3rd floor. As such, an interstitial level was added to mitigate overloading of the 3rd floor elements. With the addition of the mass to the structure, coupled with the age of construction, poor torsional response, increased recognition of seismic excitation and the desire for enhanced building performance, the client elected to retrofit the building to meet a "life safe" condition following a code level seismic event. Additionally, the sensitive communications equipment required low floor displacement and acceleration to maintain continuous operation.

The building was analyzed and exhibited severe torsional response due to the stiffness irregularity at the lower two stories. Many of the elements of these stories did not have the ductility to resist the large rotational demands as a result of the torsionally induced displacement. Additionally, large floor-to-floor heights between the ground level, 2nd level and 3rd level further magnified the floor displacement, causing undesirable effects to the sensitive equipment.

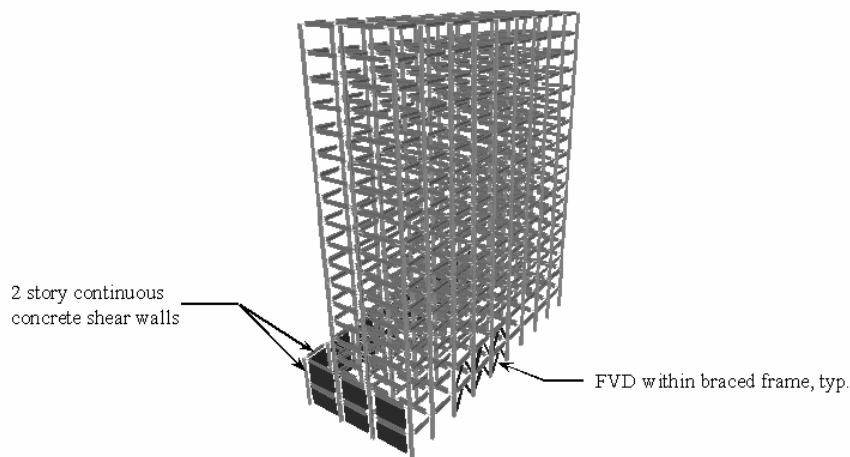

Figure 1. Three dimensional model of building.

Retrofit Philosophy

Several retrofit schemes were evaluated and presented to the client. A traditional approach could include the addition concrete shear walls or steel braced frames along a portion of the north and west sides of the building, bringing the center of rigidity closer to the center of mass. This scheme was eliminated for several reasons. Valuable storefront space would have been lost and a great deal of foundation work would have been required. The basement currently houses much of the equipment used to operate the building and disruption of this equipment was not allowed by the building owner. Also, the addition of stiff lateral force resisting elements, while decreasing floor displacement, would have drastically increased floor acceleration to unacceptable levels.

An alternative approach was to strengthen all connections that were unable to resist the ductility demand. This scheme was not incorporated for several reasons. First, the retrofit of the large number of connections required a large portion of retail space to be temporarily closed during construction. The building owner determined that this was not acceptable. Second, the cost of retrofitting the connections was very high, due to the variety of different types of welded and bolted moment connections that required upgrading. Additionally, retrofitting the connections would have done nothing to decrease the floor acceleration or displacement.

A retrofit scheme consisting of the addition of twenty FVD's was presented to the client for consideration, as it met the goals for achieving the desired performance objective at the second and third floor levels, while also being the most cost effective solution. This scheme provided a much higher overall building performance, which was considered beneficial by the building owner. The FVD's were installed within tube steel chevron braced frames (see Figure 2) along the north and west sides of the building. The FVD's were located as far away from the center of rigidity as possible, in order to maximize the effect in reducing torsional response. The addition of the FVD's was relatively unobtrusive, maintained the desired storefront, and was relatively easy to install.

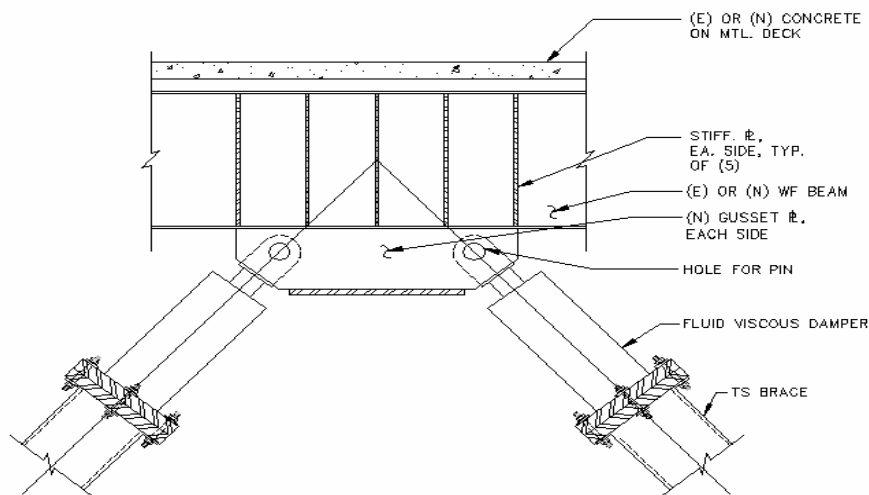

Figure 2. Damper connection detail

Input Time Histories

The building is located 5.7 km from the Hayward Fault and 24 km from the San Andreas Fault, within a region of very high seismic activity. A site-specific probabilistic seismic hazard analysis (PSHA) was performed to estimate the magnitude of the ground acceleration at the site. The PSHA modeled the nearby faults as linear sources and assigned earthquake activities to the various faults. Site-specific spectra at the ground surface were estimated using stiff soil attenuation relationships consistent with the subsurface conditions encountered at the site. Spectral matching of the spectra was performed to provide appropriate time histories for both a Design Basis Earthquake (DBE) and a Maximum Credible Earthquake (MCE). Site specific response spectra graphs for a 5% damped building are shown in Figure 3, along with corresponding UBC response spectra graphs. Time histories were chosen based on similarities in magnitude and distance to the target spectra. Three earthquakes were used for each level of seismic hazard for each direction (12 total). The worst case results for acceleration, velocity and displacement were used in design of the LFRS. The time history values are shown in Table 1.

Table 1. Time history values

Earthquake	Time History	Orientation [degrees]	Hazard Level	Peak Ground Acceleration [g.]	Peak Ground Velocity [in./sec.]	Peak Ground Displacement [in.]
Northridge (TH1)	Sylmar	360	DBE	0.625	49	14
Northridge	Sylmar	90	DBE	0.625	32.5	6.96
New Hall (TH2)	Spectra Matched	360	DBE	0.625	39.4	17.1
New Hall	Spectra Matched	90	DBE	0.625	31.3	6.45
El Centro (TH3)	Spectra Matched	230	DBE	0.625	35.5	16.2
El Centro	Spectra Matched	140	DBE	0.625	26.2	9.11
Northridge	Sylmar	360	MCE	0.751	58.8	16.8
Northridge	Sylmar	90	MCE	0.751	43.1	7.97
New Hall	Spectra Matched	360	MCE	0.751	47.3	20.6
New Hall	Spectra Matched	90	MCE	0.751	37.6	10.2
El Centro	Spectra Matched	230	MCE	0.751	42.7	19.4
El Centro	Spectra Matched	140	MCE	0.751	32.7	11.2

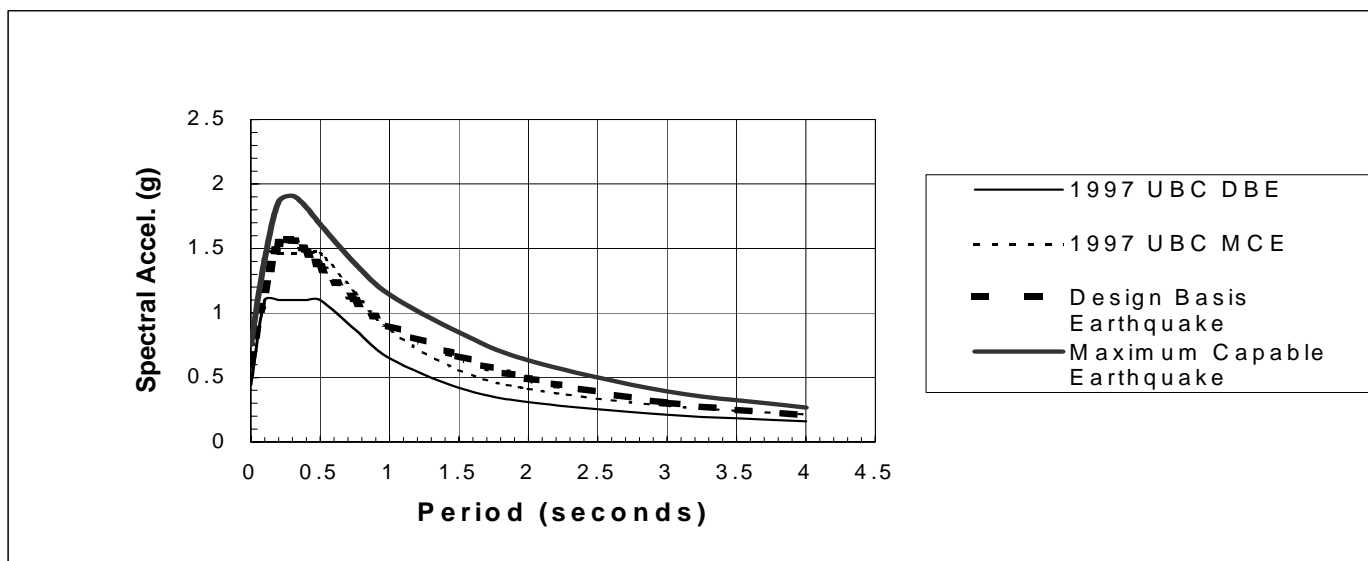

Figure 3. Response spectra graphs for 5% damped structures.

Analysis and Design Procedure

Typically, the first step in determining the effectiveness of adding FVD's to an existing structure is to build a two dimensional model, often referred to as a "stick model", and evaluate the response of the structure with supplemental damping added to various story levels. A "stick model" consists of lumped mass, stiffness, and supplemental damping at each story and is generally an appropriate tool to obtain initial quantities of damping that produce an optimal building response. However, due to the three dimensional nature of the inherent torsional irregularity in the building, a "stick model" was deemed inappropriate, thus requiring the use of a three dimensional computer model.

A three dimensional model was constructed and analyzed first without supplemental damping devices to determine the magnitude of the torsional problem. The model was constructed of elastic beam, column and connection components. A bi-directional linear time history analysis was used to determine the maximum displacement at each level (see Table 2). Ground acceleration was provided simultaneously in two directions, with scale factors of 1.0 and 0.3 for each direction to capture the increased torsional response in the building due to multidirectional ground shaking. The coupling of the 1st and 2nd modes produced drifts at the 2nd and 3rd floors exceeding the limit of maximum inelastic drift set forth in the UBC.

Incorporation of FVD's was chosen as a viable option to improve the building performance to an acceptable level because they are useful in reducing displacement, while providing little increase in force to the existing components. Discrete damping elements, within chevron braced frames, were added to the above model at the 1st and 2nd floors, in locations that were acceptable to the architect, tenant, and building owner. These discrete elements were located as far away from the center of rigidity as feasible, to maximize their effectiveness. First, linear dampers were used to simplify calculations to determine an effective damper layout. After the layout was determined, a trial and error approach was used to determine the most effective damping coefficient and nonlinear velocity exponent for FVD's in each story level, in each direction. Performing a time history analysis with linear beams and columns and nonlinear FVD's is referred to as a limited nonlinear time history analysis.

A limited nonlinear time history analysis can be a useful design tool, as it simplifies the analysis process by evaluating the beam and column elements elastically and calculating overstress factors. These overstress factors are compared to allowable values prescribed in the guidelines of FEMA 273. In addition to checking overstress factors, FEMA 273 criteria were used to check the rotational demands on the various types of moment connections throughout the building. The damping properties were iterated until all elements met FEMA requirements.

The braced frames, as well as the connections of the braces to the FVD's and to the existing structure were designed using a force resulting from a velocity of 1.3 times the velocity associated with a MCE level event. This force level ensured the braced frame and connections would have the required strength and stiffness to effectively engage the FVD's. Various collector beams and beam/column connections were strengthened to meet the demand associated with the force in the FVD's. Strengthening of the collector connections was accomplished by welding of the existing bolted connections. Welding was chosen because it provided the required strength to resist the demand, as well as providing increased stiffness of the collector element, thereby increasing the effectiveness of the FVD's.

A nonlinear static pushover analysis was performed to verify the results of the limited nonlinear time history analysis. The pushover analysis was utilized to substantiate the simplification of incorporating elastic elements in the limited nonlinear time history analysis and to determine the adequacy of the individual elements to withstand the rotations associated with a DBE level response spectrum. FEMA 273 guidelines were used to perform the pushover analysis with moment-curvature hinges provided at each beam and column. The “target displacement” used for the analysis was the displacement obtained from the limited nonlinear time history analysis. This displacement was selected based on the fact that the true building displacement under a design level seismic event would be approximately equal to the displacement of a “linear” structure subjected to unreduced seismic forces. Due to the dynamic nature of the structural irregularity, the pushover loads were based on the story shear forces obtained from the response spectrum analysis. This load distribution takes into account the coupling of the first two modes, as the story shears are the result of a combination of several modes. Additionally, a uniform load distribution was analyzed. A discussion of the results of the analyses is presented below.

The above analyses and design were peer reviewed by a structural engineer experienced in energy dissipation systems, as prescribed in the SEAOC Blue Book (SEAOC, 1999). Additionally, each damper was tested to confirm force-displacement properties assumed in design and to verify the robustness of the individual devices under extreme seismic excitation.

Analysis Results

The results of the computer model for the existing building without dampers indicate the 2nd and 3rd floors experience drifts exceeding the maximum allowable drift set forth in the UBC. The results indicate the incorporation of FVD's reduced the displacement at the 2nd and 3rd floors by up to 40% (see Table 2). The displacements on the stories above the 3rd floor decreased by up to 25% (see Table 2). The benefit of the dampers on the building's displacement decreased relatively linearly from the 4th floor to the roof, with the roof experiencing 7% less displacement with the FVD's. The floor acceleration decreased by up to 27% at the 2nd and 3rd floor with the incorporation of FVD's. The floors above the 3rd floor also experienced a decrease in acceleration, with the roof acceleration decreasing by about 15%. Similarly the lateral forces on the individual elements decreased in proportion to the change in acceleration. Therefore, the installation of dampers on the first two stories drastically increases the performance on the upper stories.

The pushover analysis indicated the building is capable of reaching the expected maximum displacement. Based on FEMA 273 (FEMA, 1997), the building is capable of achieving a “life safe” condition at a DBE level event. Under an MCE level event, the building meets a “collapse prevention” service level. For this particular case, a pushover analysis has some limitations. Namely, the torsional irregularity at the lower two stories was captured with the dynamic analysis, however the static pushover analysis produced slightly different results for the 2nd and 3rd story drifts, as expected. The pushover was a useful tool in analyzing the rotational capacity of individual elements that would likely experience nonlinear behavior. The limited nonlinear time history analysis, together with the nonlinear pushover analysis, provides a reliable means of analyzing a building with FVD's incorporated to resist torsion.

Table 2. Analysis Results – Reduction in floor displacement

Story	Direction	Displacement w/out Dampers (in.)	Displacement w/ Dampers (in.)	Percent Decrease
2nd	X	1.31	0.79	40
2nd	Y	4.05	2.62	35
3rd	X	3.25	2.16	34
3rd	Y	10.15	7.42	27
4th	X	5.22	4.41	16
4th	Y	13.63	10.26	25
Roof	X	55.4	54.9	1
Roof	Y	72.4	67.6	7

Table 3. Analysis Results – Reduction in floor acceleration

Story	Direction	Acceleration w/out Dampers (in/sec ²)	Acceleration w/ Dampers (in/sec ²)	Percent Decrease
2nd	X	361	276	24
2nd	Y	714	539	25
3rd	X	618	482	22
3rd	Y	1455	1057	27
4th	X	641	501	22
4th	Y	1509	1199	21
Roof	X	1154	1002	13
Roof	Y	2976	2494	16

Conclusions

The incorporation of FVD's can be a very cost effective and practical method of reducing the torsional response as a result of a "property line" condition. The FVD's eliminated the need for any other major structural strengthening of the LFRS, including any improvements to the foundation system. The dampers not only reduced the demand on the floors at which they were installed, but also reduced the demand on the 16 stories above. The entire building benefited from the incorporation of a few well-placed FVD's at the lower stories. Additionally, the decrease in floor displacement and acceleration greatly reduced the susceptibility of damage to the sensitive communications equipment.

References

- CSI, 1999, *ETABS – Integrated Design and Analysis Software for Building Systems*, Computers and Structures, Inc., Berkeley, CA.
- ICBO, 1997, *Uniform Building Code*, International Conference of Building Officials, Whittier, CA.
- FEMA , 1997, *NEHRP Guidelines for the Seismic Rehabilitation of Buildings*, Federal Emergency Management Agency, Washington, D.C.
- SEAOC, 1999, *Recommended Lateral Force Requirements and Commentary*, Seismology Committee, Structural Engineers Association of California, Sacramento, CA.
- Singh, J.P., 1998, *Site Specific Ground Motion for High-Tech Seismic Design*, U.S.-Japan Workshop on the Improvement of Structural Design and Construction Practices, Honolulu, HI